

Access Control Module



User's Guide

System Requirements

Technical support for this application is available from your local dealer.

Gatehouse®, is a registered trademark of TEM systems.

Microsoft® and Windows® are trademarks of Microsoft corporation.

Windows NT® and Windows 95® are trademarks of Microsoft Corporation.

Access Control

Revision a5

Document Number 9071

Print Date August 2002

This manual is proprietary information of [TEM systems](http://www.temsystems.com). Unauthorized reproduction of any portion of this manual is prohibited. The material in this manual is for informational purposes only. The information is subject to change without notice. TEM Systems assume no responsibility for incorrect information this manual may contain. www.temsystems.com

© 2002

TEM Systems, Inc. Software License Agreement

PLEASE READ THE FOLLOWING TERMS AND CONDITIONS CAREFULLY BEFORE USING THIS SOFTWARE. YOUR USE OF THIS SOFTWARE IS SUBJECT TO THIS SOFTWARE LICENSE AGREEMENT.

BY YOUR USE OF THE SOFTWARE YOU AGREE TO BE BOUND BY THE LICENSE TERMS AND CONDITIONS SET FORTH HEREIN. IF YOU DO NOT AGREE TO BE BOUND BY THE TERMS AND CONDITIONS, YOU MUST PROMPTLY RETURN THIS SOFTWARE TO TEM. UPON RECEIPT OF THE SOFTWARE, YOUR LICENSE FEE WILL BE REFUNDED.

TEM Systems, Inc. ("TEM") Software License Agreement

In return for acquiring a license to use the TEM software, which may include software from third party licensors and patches made available by TEM ("Software"), and the related documentation, you agree to the following terms and conditions:

1. License. TEM hereby grants you the nonexclusive right to:
 - a) use the Software on a single computer system [OR NUMBER OF SYSTEMS], which is not intended for use by more than [NUMBER OF USERS] users;
 - b) make one copy of the Software in machine readable form solely for back-up purposes, provided you reproduce TEM's copyright legends;
 - c) use the documentation, if any, in the United states during the term of this Agreement in support of your use of the Software.
2. Restrictions. You agree that you may not:
 - a) distribute copies of the Software to others or electronically transfer the Software from one computer to another over a network;
 - b) post or otherwise make available the Software, or any portion thereof, in any form, on the Internet;
 - c) use the Software in a computer service business, including in time sharing applications;
 - d) reverse engineer, disassemble, or otherwise reduce the Software to a human-perceivable form (and in connection with this you recognize that the Software contains TEM trade secret information);
 - e) MODIFY, ADAPT, TRANSLATE, RENT, LEASE, LOAN, RESELL FOR PROFIT, DISTRIBUTE, NETWORK OR CREATE DERIVATIVE WORKS BASED UPON THE SOFTWARE OR ANY PART THEREOF.
3. Ownership of Software. As Licensee, you own the media upon which the Software is recorded or fixed, if any, but TEM and its licensors retain title and ownership of the Software recorded on the original media and all subsequent copies of the Software, regardless of the form or media in which or on which the original and other copies may exist. THIS LICENSE IS NOT A SALE OF THE SOFTWARE OR ANY COPY.
4. Confidentiality. You agree to maintain the Software in confidence and that you will not disclose the Software to any third party without the express written consent of TEM. You further agree to take all reasonable precautions to preclude access of unauthorized persons to the Software.
5. Term. This license is effective until January 1, 2010, unless terminated earlier. You may terminate the license at any time by destroying the Software (including the related documentation) together with all copies or modifications in any form. TEM will have the right to terminate the license immediately if you fail to comply with any provision of this Agreement. Upon any termination, including termination by you, you must destroy the Software (including the related documentation), together with all copies of modifications in any form.
6. Special Terms Applicable to Databases. Where a database is included with the Software, you acknowledge that it is licensed only in connection with the use of the Software, and that the database and all data derived therefrom must be maintained in confidence in accordance with the provisions of Section 4. This license does not grant you any rights to distribute or disclose such database or data.
7. LIMITED WARRANTY -- LIMITATION OF REMEDIES AND LIABILITY.
 - a) TEM warrants only that the media upon which the Software is furnished will be free from defects in material and workmanship under normal use and service for a period of thirty (30) days from the date of delivery to you. YOUR SOLE AND EXCLUSIVE REMEDY, AND TEM'S SOLE LIABILITY, IS TO REPLACE THE DEFECTIVE MEDIA OR, IF YOU REQUEST, TO REFUND TO YOU THE LICENSE FEE FOR THE SOFTWARE AND DOCUMENTATION, PROVIDED THAT YOU NOTIFY TEM IN WRITING OF SUCH DEFECT AND RETURN TO TEM THE DEFECTIVE MEDIA CONTAINING THE SOFTWARE AND THE DOCUMENTATION, DURING THE ABOVE THIRTY (30) DAY WARRANTY PERIOD, AT THE FOLLOWING ADDRESS: TEM Systems, Inc., 4880 North Hiatus Road, Sunrise, Florida 33351.
 - b) EXCEPT AND TO THE EXTENT EXPRESSLY PROVIDED IN PARAGRAPH 7(a), TEM DOES NOT AND CANNOT WARRANT THE PERFORMANCE OR RESULT YOU MAY OBTAIN USING THE SOFTWARE OR DOCUMENTATION. THE SOFTWARE AND DOCUMENTATION ARE PROVIDED ON AN "AS IS" BASIS, WITHOUT ANY WARRANTIES OF ANY KIND, INCLUDING, BUT NOT LIMITED TO, ANY IMPLIED WARRANTIES OF MERCHANTABILITY OR FITNESS FOR ANY PARTICULAR PURPOSE. YOU ASSUME THE ENTIRE LIABILITY FOR THE SELECTION AND USE OF THE SOFTWARE AND DOCUMENTATION, AND TEM SHALL HAVE NOT LIABILITY FOR ANY ERRORS, MALFUNCTIONS, DEFECTS, OR LOSS OF DATA RESULTING FROM OR RELATED TO THE USE OF THE SOFTWARE AND/OR DOCUMENTATION.
 - c) TEM SHALL NOT BE LIABLE TO YOU FOR ANY INCIDENTAL, SPECIAL, CONSEQUENTIAL OR INDIRECT DAMAGES, INCLUDING ANY LOST PROFITS, LOST SAVINGS, OR LOSS OF DATA, EVEN IF TEM HAS BEEN ADVISED OF THE POSSIBILITY OF SUCH DAMAGES, OR FOR ANY CLAIM BY ANY OTHER PARTY.
8. Export. You acknowledge that the laws and regulations of the United States and other countries may restrict the export and re-export of the Software. You agree that you will not export or re-export the Software or documentation in any form in violation of applicable United States and foreign law.

9. Government Restricted Rights. The Software is subject to restricted rights as follows. If the Software is acquired under the terms of a GSA contract: use, reproduction or disclosure is subject to the restrictions set forth in the applicable ADP Schedule contract. If the Software is acquired under the terms of DoD or civilian agency contract, use, duplication or disclosure by the Government is subject to the restrictions of this Agreement in accordance with 48 C.F.R. 12.212 of the Federal Acquisition Regulations and its successors and 49 C.F.R. 227-7202-1 of the DoD FAR Supplemental and its successors.

10. General Provisions. You acknowledge that you have read this Agreement, understand it, and that by using the Software you agree to be bound by its terms and conditions. You further agree that it is the complete and exclusive statement of the agreement between TEM and you, and supersedes any proposal or prior agreement, oral or written, and any other communication between TEM and you relating to the subject matter of this Agreement. No additional or any different terms will be enforceable against TEM unless TEM gives its express consent, including an express waiver of the terms of this Agreement, in writing signed by an officer of TEM. You assume full responsibility for the use of the Software and agree to use the software legally and responsibly. This Agreement shall be governed by Florida law, entered into at Fort Lauderdale, Florida by both parties. The parties agree that that the courts of Broward County, Florida shall have exclusive jurisdiction and venue of any action arising out of this Agreement or relating in any way to the Software. Should any provision of this Agreement be declared unenforceable in any jurisdiction, such provision shall be deemed severable from this Agreement and shall not affect the remainder hereof. All rights in the Software not specifically granted in this Agreement are reserved by TEM Systems, Inc.

If you have any questions concerning this Agreement, you may contact TEM by writing to:

TEM Systems, Inc.
Legal Department
4880 North Hiatus Road
Sunrise, Florida 33351

Table of Contents

CHAPTER 1 INSTALLING GATEHOUSE® ACCESS CONTROL MODULE	1
HARDWARE REQUIREMENTS	1
SOFTWARE INSTALLATION	2
CHAPTER 2 STARTING THE ACCESS CONTROL MODULE APPLICATION.	3
<i>Actlservice.exe</i>	3
✓ <i>Accesslog.exe</i>	3
✓ <i>Readersinc.exe</i>	3
✓ <i>Lim.exe</i>	3
<i>Ghcardaccess.exe</i>	3
CHAPTER 3 NAVIGATING GATE HOUSE® ACCESS CONTROL MODULE ...	5
ACCESS CONTROL SCREEN	5
USING THE EXPANDABLE TREE TO NAVIGATE THE SYSTEM	5
ACCESS CODES	9
AUTOMATION ICON	10
CARDHOLDERS MENU	11
CARD ACCESS NODE ICON	12
DOOR MONITORING CONTROLS	13
<i>Reader Name</i>	13
<i>Reader Format</i>	13
<i>Strike time</i>	13
<i>Door Monitor</i>	13
<i>Exit Monitor</i>	14
<i>Neutral</i>	14
<i>Facility Mode</i>	14
<i>Offline</i>	14
<i>Special</i>	14
<i>Inbound</i>	14
<i>Outbound</i>	14
CHAPTER 4 ACM MINI-APPLICATIONS	15
ACTLSERVICE.EXE	15
<i>Status</i>	15
<i>Service</i>	16
<i>Monitor</i>	17
<i>Cards</i>	17
<i>Door Control</i>	18
<i>Options</i>	19
<i>Door control</i>	20
READERS.EXE	20
ACCESSLOG.EXE	21
CHAPTER 5 SYNCHRONIZER – LINK	22
CHAPTER 6 TROUBLESHOOTING.....	23
<i>ACM Configuration changes don't get saved</i>	23

CHAPTER 7 TUTORIAL.....	24
ASSIGNING ACCESS CARDS.....	24
FACILITY CODE.....	25
CHANGING THE ACCESS CARD RANGE.....	25
CHAPTER 8 CONNECTION DIAGRAMS	27
GATEHOUSE AMTECH CONNECTION DIAGRAM.....	27
CYPRESS BOARD POWER CONNECTIONS.....	27
CYPRESS CVT-2110 AMTECH DATA CONNECTION	28



Chapter 1 **Installing Gatehouse® Access Control Module**

Hardware Requirements

HARDWARE REQUIREMENTS

Processors and Chipset

Intel® Pentium® III 800 MHz or better processor

Intel® Celeron™ 733 MHz processor with at least 32 KB L1 Cache, 128 KB Internal L2 Cache or better

Memory

128 MB (100 MHz SDRAM DIMMs)

Storage

20 Gig (5400 RPM) Ultra ATA-100 hard drives or better

3.5", 1.44 MB diskette drive

40x max or better variable speed CD-ROM

Audio

SoundBlaster™ or compatible Sound Card

Video and Monitors

17" (13.8" viewable .26 dpi)

Graphics card capable of displaying 16M Colors at 1024x768

Slots

4 PCI slots or more

Ports

1 Parallel port

2 High-speed serial ports

Speaker Phone

1 Voice Modem

Network

1 56K HAYES COMPATIBLE MODEM IS REQUIRED FOR EACH WORKSTATION UTILIZING DIALUP CONNECTIVITY

1 10/100 ETHERNET CARD IS REQUIRED FOR EACH WORKSTATION UTILIZING ETHERNET CONNECTIVITY

(3Com® Etherlink® 10/100 PCI network interface card part# 3CP905B-TX-NM)

1 10/100 ETHERNET HUB/SWITCH IS REQUIRED WHEN CONNECTING MORE THAN ONE WORKSTATION PER SEGMENT

(3Com® OfficeConnect® Dual Speed Switch 8 part# 3C16734B-US) or

(3Com® OfficeConnect® Dual Speed Switch 4 part 3C16733A-US)

Chapter 2

Starting the Access Control Module application

The Access Control Module, ACM for short, consists of several applications woven together uniquely via the software. The 2 main programs are the ACM Engine (actlservice.exe) that runs in the system tray, and ACM (ghcardaccess.exe) that is used to configure the engine.

Upon installing the ACM, the following mini-applications are installed on your computer in the ACTLSERVICE Folder.

Actlservice.exe

This is the engine that runs in your system icon tray (the group of icons near the clock). The following 3 applications are automatically started upon ‘running’ the Actlservice (access control engine).

- ✓ **Accesslog.exe**

This module writes the activity log to disk for history reporting.

- ✓ **Readersinc.exe**

This module “show’s the readers information” on the main console.

- ✓ **Lim.exe**

This module is used to check if the connection is persistent, if for any reason the connection drops, this module will save the ACM data to a data file. This allows the system to be restarted even if the original network path pointing to the database file is not available. If during a network failure, the connection to the main server is lost, the system will continue to function like normal. **Note:** Obviously, you can’t add new records while in this mode.

Ghcardaccess.exe

This is the main application used to configure the engine for you’re site. Most of the manual is dedicated to the configuration of this application. The following parameter of MTR will display the real-time monitor on the screen, rather than opening the entire ACM application. You would could create a shortcut on your desktop and use “GHCARDACCESS MTR” as the command line.

Exiting the Gatehouse® Access Control application and engine

If you are using the ACM application, click the file menu, and highlight the Exit option.

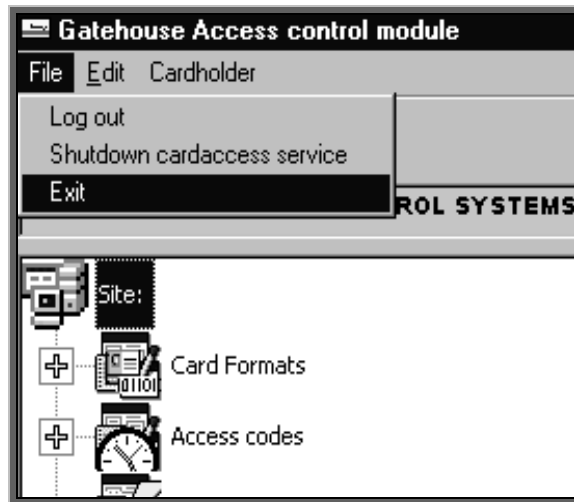

If you want to exit the driver located in the system icon tray (this will shutdown the module and the gates will not automatically open/close/lock/unlock), move your mouse over the icon, right click, you will see a menu, select "Configure". Select the "Service tab", click the "Shutdown" button.

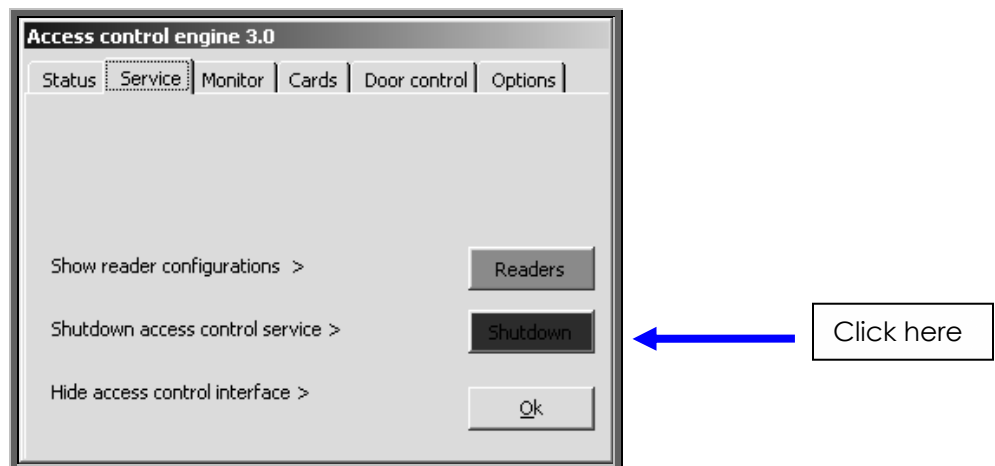

Chapter 3

Navigating Gate House® Access Control Module

Access Control Screen

The ACM is designed with an expandable tree like system to move between functions. The right side of the screen displays options for each of the functions that can be selected in the tree.

The ACM allows for administration and management of the security access system for the entire community through a single integrated interface.

The Gate House® ACM integrates with the Gate House® Administrative Interface. When assigning access cards to either a new or existing resident in the Administrative Interface, the module interacts with the changes in the database.



Using the expandable tree to navigate the system

The user can expand or collapse the tree to access the various functions. The tree is similar to Windows® Explorer. The “home” icon in this tree is the site icon. When the user clicks on this icon, the menu to the right displays the available options pertaining to the selected set of functions.

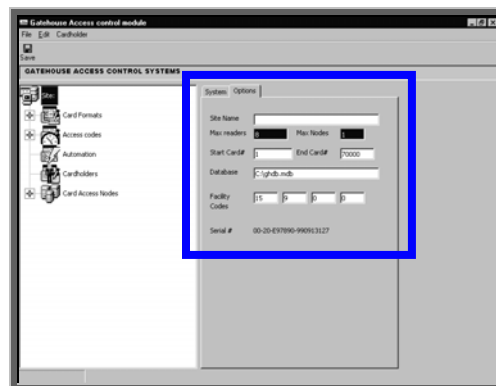

The main icon in the expandable tree is the site or home icon. The menu option field to the right will display options associated with the icon. The site icon contains fields to select the database file that will be used to read the cards, the number of readers to be used with the system, the number of cards, and the facility code that the site uses. A facility code is an additional number on the card to further uniquely identify the access card to this site.

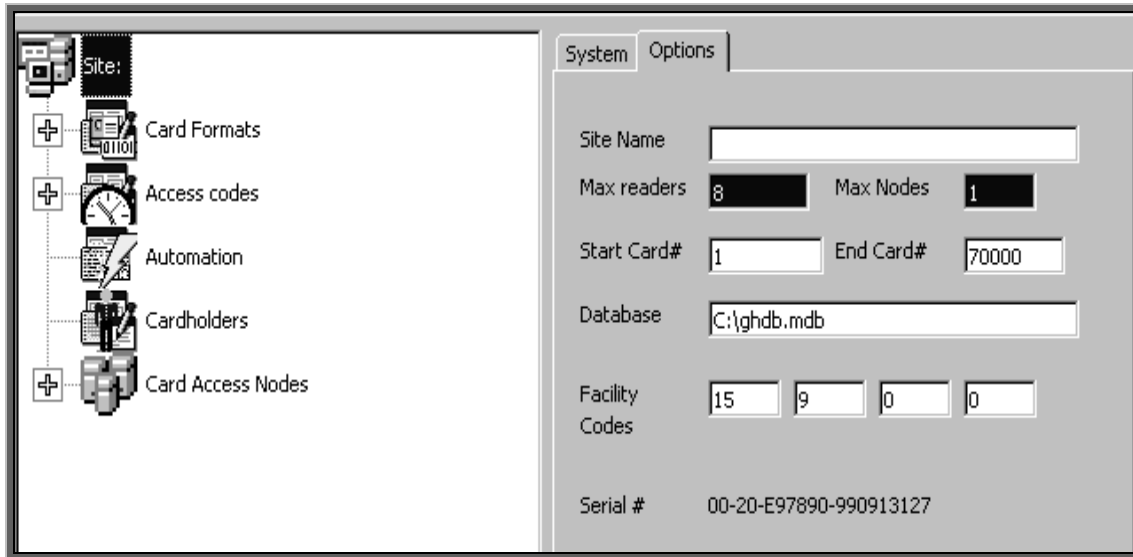

The following table describes the fields used on the site icon tab.

<u>In this field</u>	<u>What it does</u>
Site Name	The name of the site.
Max readers	Set the number of card readers the system will use.
Max Nodes	Set the number of nodes, or control points in the system.
Start Card#	The first number of the range of access cards.
End Card#	The last number of the range of access cards.
Database	The logical path where the database file is located in the computer. This can be a drive letter on the local drive, a mapped network drive, or a UNC network name.
Facility Code	An extra number assigned to a group of access cards to make the card unique to another access card with the same I.D. number to gain access to another community.
Serial #	The I.D. number of the software.

Card Formats

The process of setting up the card format is to:

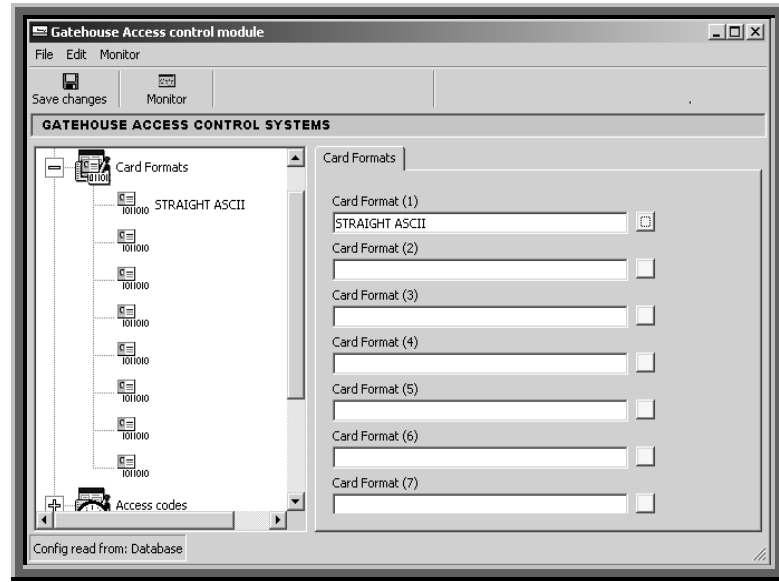

In the card formats section of the tree view, select the Card Format's. You will then see a screen resembling the one above. You can give a name to your format by typing it in the Format Name field. In our example, we use the "STRAIGHT ASCII" format. The next field, Interface Type, gives you the following choices as displayed in the picture below.

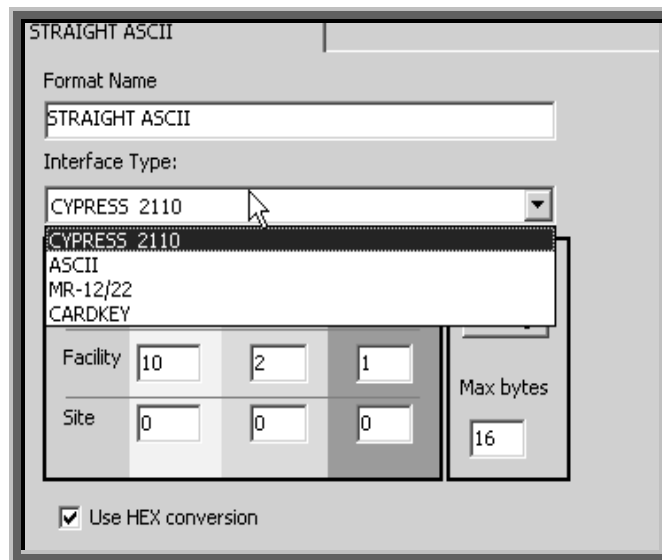

Cypress 2110

Data is in Weigand format and needs to be converted to ASCII.

ASCII

Raw ASCII data format, this does not need to be converted.

MR-12/22

Swipe card type reader, this does not require Cypress Boards

Cardkey

This format is a specialized format that is not used often.

Max Bytes

This is the total number of bytes expected in the string read by the reader device.

Config

Clicking button allows the program to use the Extended card format instead.

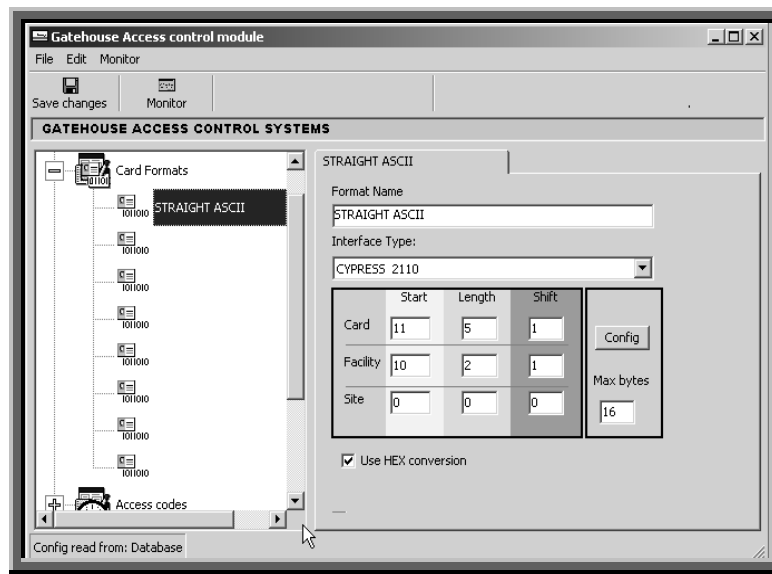

NOTE:

The program first looks for the formats in the extended codes, and then if it does not find anything, it then looks at the card format setup. This provides 'a tool' to allow the user to setup some configurations.

Access Codes

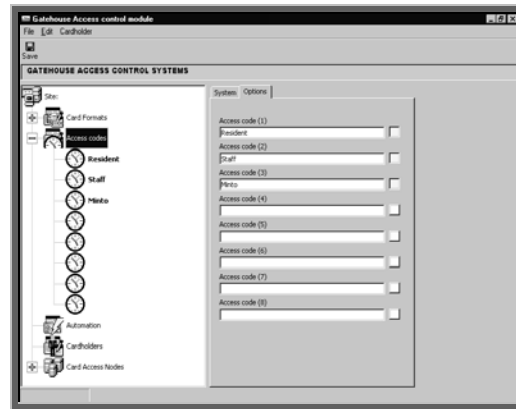

The Access code icon allows the user to create access levels. The access levels are broken into days and hours and special functions.

The administrator can create access levels and name them, for example, an access level named Residents can be created with full access to the site.

If a community wants the access cards to work only from 6:00am to 10:00pm at one or all of the gates, you would enter a starting time of 06:00am and ending time of 10:00pm. Access to the gate or door will be denied if someone tries to use the card at any time other than in the range specified. This would be useful to limit the use of certain community gates, and force residents (or residents that have this access level) to use the main gate. Since there are multiple access levels, this can be configured any way you like.

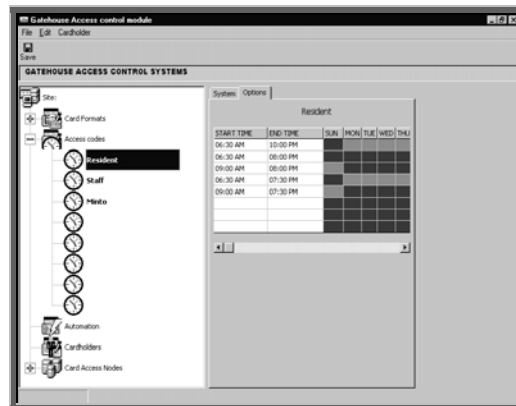

The administrator can create up to 8 levels of access, one for the residents, one for employees, another for staff, and still have some space to create other unique access levels. The access codes are presented as a bar graph, where by simply double-clicking the square will change the clearance from RED (no access) to GREEN (access) These squares work as buttons allowing the administrator to turn it on or off simply by clicking on it.

By clicking the name of the access level in the tree, this will display the day and time of the level.

In the access code menu the following fields should be entered: The start and end time, the day of the week, and at which entry gate the card can access. As the image below shows, an access level can have more than one time zone.



Automation Icon

The automation icon is an auto-unlock scheduling system. This gives the administrator the option to schedule when a gate opens and closes.

Some communities have auto unlock schedules that start in the morning. For example, the exiting gates open at 6:30 am in the morning; this allows the residents to leave the community without stopping and waiting for the exit gates to cycle open. At 9:00am, the system can close the gates, since most the residents would have already left the community for their daily activities. The system would now leave the auto unlock mode and return to normal operation. There is a slight security risk, where outsiders are able to enter the community through the exit gates, but this is up to the administrator if you want to enable this option.

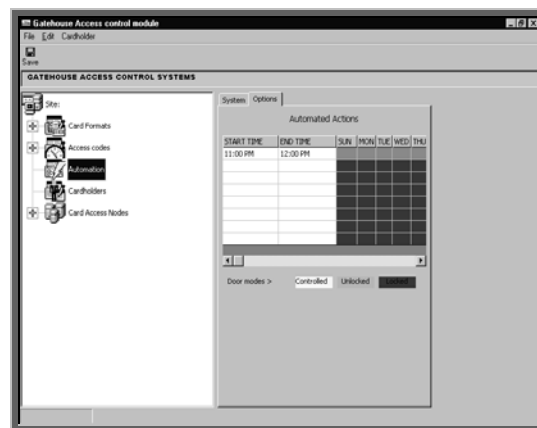

The time zone for the auto unlock schedule is similar to the access code menu. There are start and end times, days of the week for which gate this function activates.

The time zone also has door modes; the door modes have three states, controlled, unlocked, and locked. The door modes set in what state the gate or pool door is in.

The controlled state is normal mode which is how you would leave your system most of the time. The controlled state checks whether the card has access and responds appropriately. The unlocked state will open the gate and keep it open until the system closes or returns to normal mode.

The locked mode, as the name implies, will keep the gate closed or locked down until the system is returned to the normal (controlled) mode or a unlock command is issued.

The locked mode is best to use when using a gate that is securing a loading dock that is closed for the evening. In the automation menu there are fields to enter the start and end time, the day of the week, and at which gate the action will perform. As the image below shows an example of a automated action.



Cardholders Menu

In this menu the administrator can assign access cards to residents, employees, or staff. The administrator would enter the card number, the name of the cardholder, select an access level and when the access card is active and or expires. Near the bottom of the screen, there is a search field to locate either by the card number or cardholder.

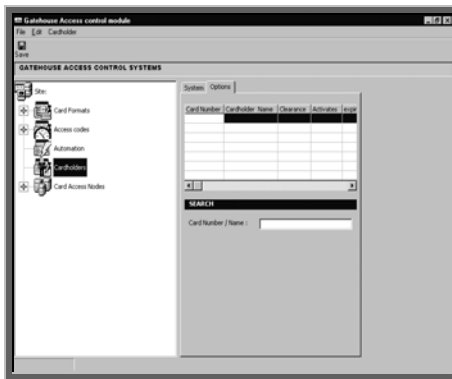

The access control system also interacts the Gate House® Administrative Workstation. Instead of entering all the cardholder information, and access level in the module, the Administrative Workstation interface will manage assigning the access cards.

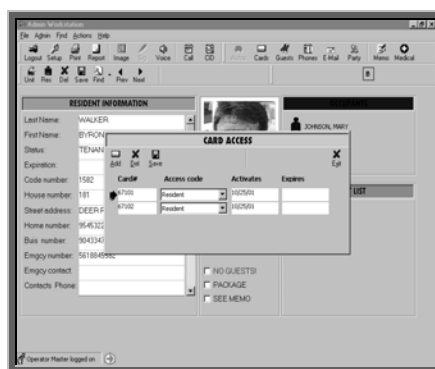

Card Access Node Icon

Nodes allow the administrator to define access controllers on the system that can be controlled and whether they are Online or Offline. Online means that the node is waiting for an event to take place and trigger the action. Offline shows that the node is not going to take any action not matter what the event is. If the node is Online, you will see that node under the Card Access Nodes tree.

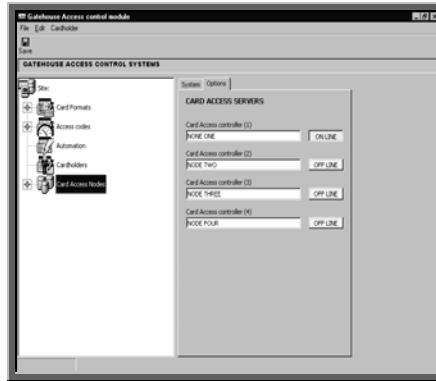

If you click on the Nodes Icon, you will see a screen on the right containing various configuration properties. Most of these settings should not be modified.



If you click on the tree portion of the nodes icon, you will be able to see the ports configuration area. This allows you choose the communication ports your system is using. Example. The machine already has 2 built in COM ports, COM1 and COM2; the system you're setting up requires 4 additional ports. You have purchased a multiport I/O card that starts on COM5 thru COM8. In the ports configuration screen you need to assign these new COM ports. Each COM port correlates to the name of the door or gate or location.

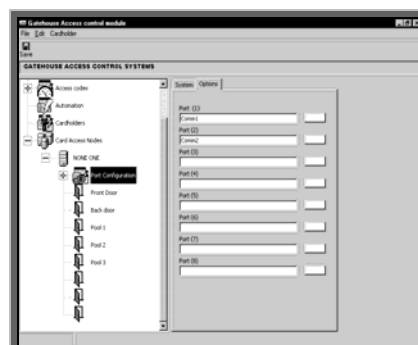

In the display below, you can see the 8 COM ports displayed.

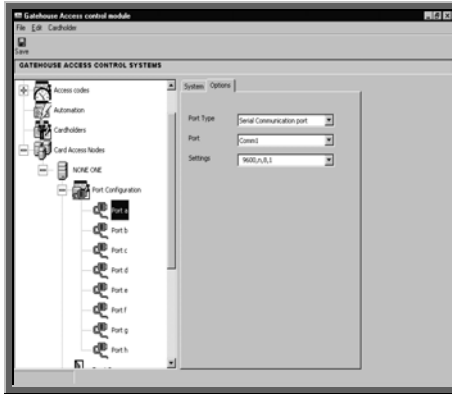

The port letters directly reflect the position of the reader names (directly underneath the port configuration. For instance, A=1,B=2,etc. If you have a device in COM1, but it's in the 3rd position, then you need to go port "C" and make sure that COM1 is selected.

Door Monitoring Controls

The Access Control system also provides a setting to monitor the status of a door or gate.



Reader Name

This is the name that you called the reader.

Reader Format

This displays a drop-down menu showing the different reader formats that are available to be configured for this reader.

Strike time

The pulse time to send a command to the door to open it

Door Monitor

On a clubhouse door, the system will sound an alarm if the door opens without a card passing through it first. This would not be used for a gate entry system.

Exit Monitor

If a person tries to exit a clubhouse door without entering a code from the other side. The exit monitor will sound an alarm if the door opens and the system does not sense that anyone left the property and only entered through the door. This would not be used for a gate entry system.

There are several modes the reader can be set to:

Neutral

This is the standard mode, where the system denies or grants access by reading the card.

Facility Mode

This mode allows access of any cardholder that has a card that is in the same facility code as the complex they are trying to enter.

Offline

Access to this door or gate is shutdown. Door or gate cannot be controlled from the software until it's back online.

Special

Example. The resident wants a special signaling when their child comes into the property. Once the child comes into the property the flag is cleared that the child is now home from school. At predetermined time, the guard can then run a report for all the children that have not returned back into the property, and notify the parents of the situation.

The following 2 modes are using a form of Anti-passback. Anti-passback prevents a person from "passing back" a card for another person to use, and detects when someone "tailgates", or follows another car or person through a door without using his or her own access card.

Inbound

This works in conjunction with the outbound option. What happens is the system will not allow the same card number to come back "in" to the property until he "left" (outbound) the property. This prevents the same card from being used over and over to enter the property. The audit trail will reflect this warning by displaying "passback or anti-passback message.

Outbound

This works in conjunction with the inbound option. What happens is the system will not allow the same card number to come back "in" to the property until he "left" (outbound) the property. This prevents the same card from being used over and over to enter the property. The audit trail will reflect this warning by displaying "passback or anti-passback message.

Chapter 4

ACM Mini-Applications

As described briefly at the beginning of this manual, here in more detail are the mini-applications that make up the ACM engine.

Actlservice.exe

This is the engine that runs in your system icon tray (the group of icons near the clock). The following 3 applications are automatically started upon ‘running’ the Actlservice (access control engine).

When ACM engine is running it’s displayed in the system icon tray as a mini-tower computer.

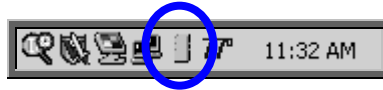

When you RIGHT-CLICK on the engine icon, you will see a menu displayed similar to the following picture.

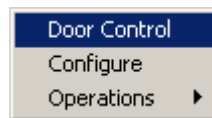

Selecting the Configure option, will display the main ACM engine window. This window consists of 6 tabbed screens. Status, Service, Monitor, Cards, Door Control, and Options. The tab used most often will be the “Service tab”. This contains the invaluable “Readers” button. We will now go into detail on all of the options in the ACM Engine.

Status

This displays the current door states. This tab displays wealth of information related to the status. In the Following example the top of display shows the current door state showing door’s 1 and 2 unlocked (Green), the remaining doors are (Yellow) (“neutral” controlled mode). On the bottom of the display are valid doors for the access code presented through the card. In this example all the doors are (Red) indicating that the cardholder will be able to gain access at this time. This could be for several reasons; either the card has been presented to a door the cardholder does not have access to, or the cardholder presented the card to a gate that is currently locked because it could be only used during certain hours. There are several other possibilities, but we won’t get into that at this point.



The valid doors for this authorization code displays the name of the access code previously defined.
Example, Residents, Security, Employees, etc.

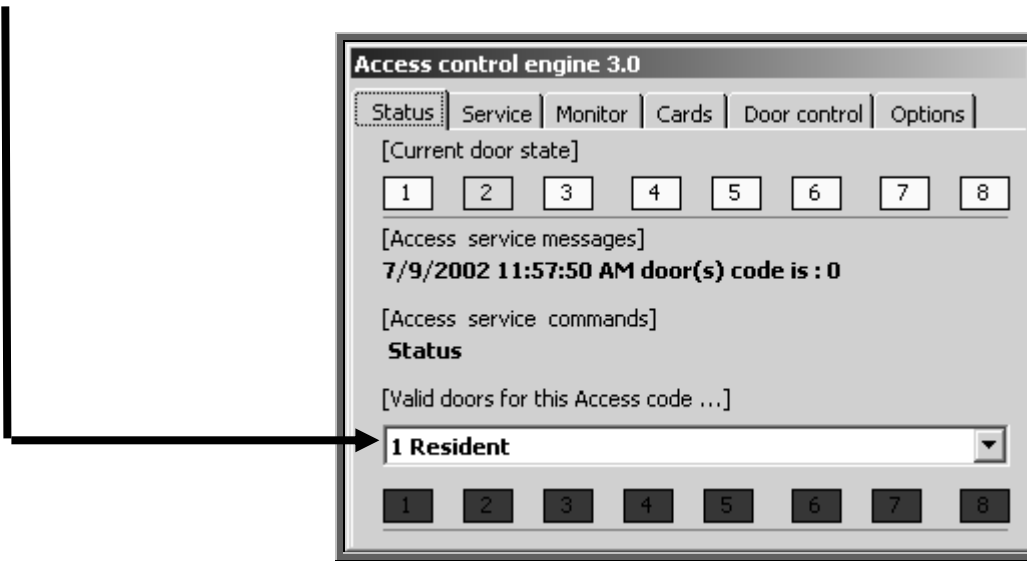

The above shows a cardholder with the “Resident” access level.

Service

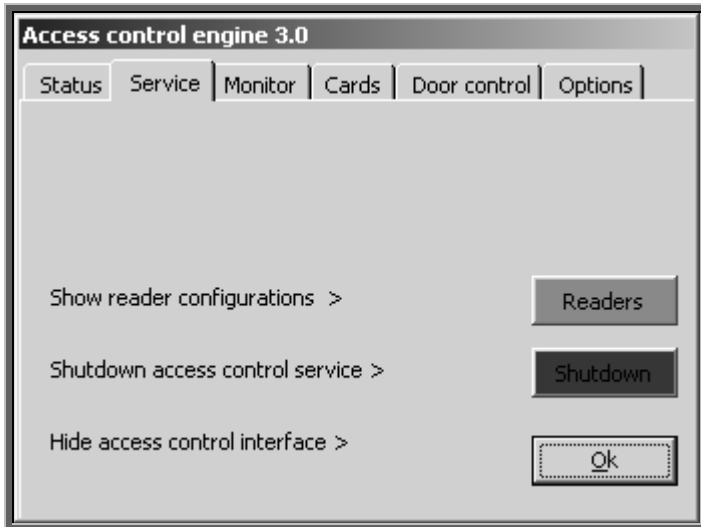

Monitor

The monitor tab displays history about the status of the database etc.

The following displays shows the ACM Engine was started up on 07/09/2002 at 11:55am. The next items show that settings were loaded, the node ID is 1, and the Engine mode is 1 (these will be described further later in this chapter), and most importantly, we were able to read the card database from the source. The next thing displayed is that the reader was started on the left lane. The readers get started in the order of their entry in the node's setup from ACM.

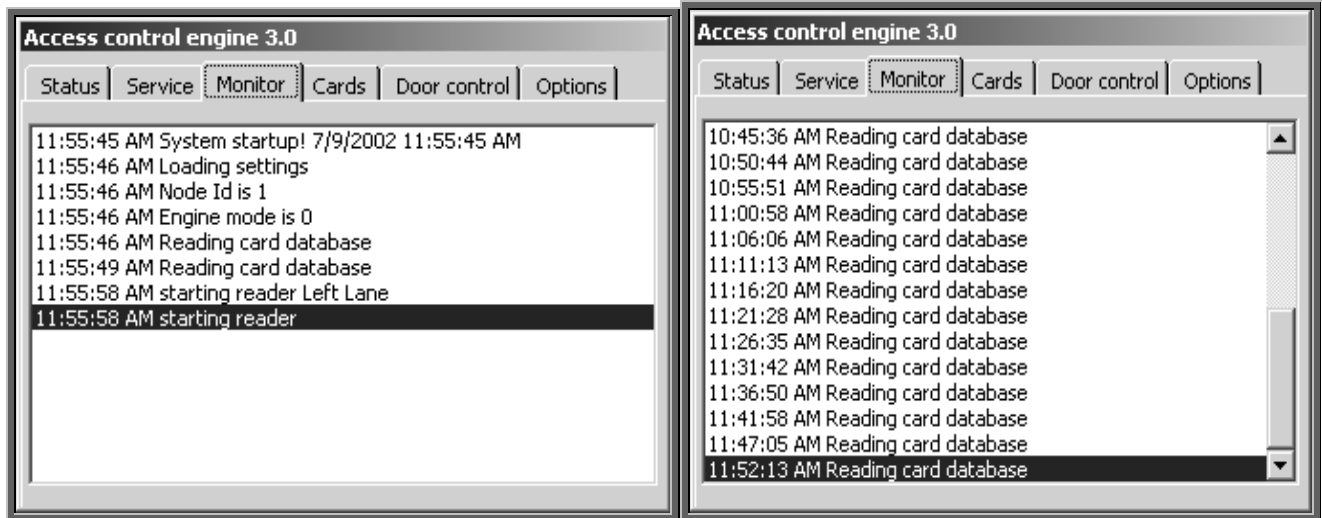

The engine is useful at times to verify that the “READING CARD DATABASE” appears. This indicates that the ACM engine was successful in reading the database from source. If there were an error, the error would be also displayed in the monitor tab.

Cards

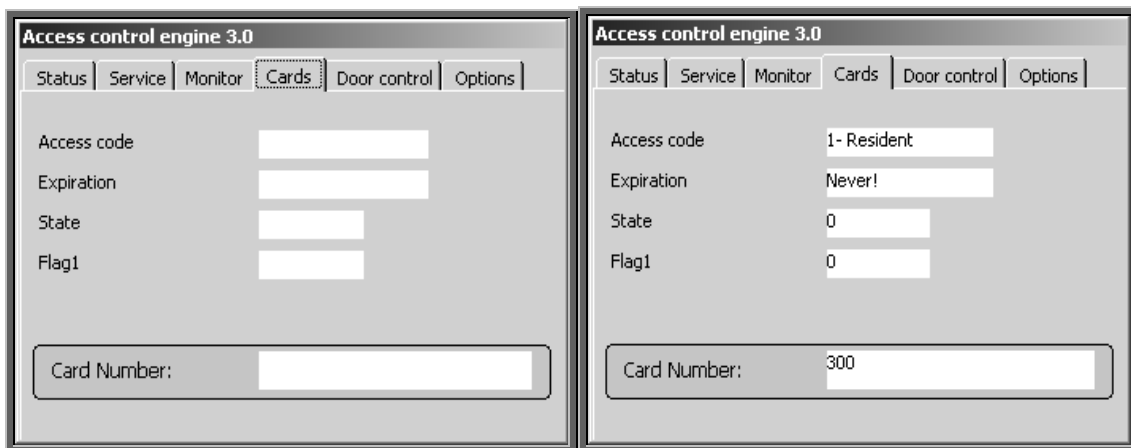

The cards tab allows you to enter a card number into the Card Number field, and the ACM will look up the card to verify it's a valid card. In the example above, we entered in card #300, the system looked up that card and displayed that the Access Code=1 (Resident) and Expiration=Never. It's important to note that this information is not necessarily looked up from the Database file, but from the temporary ACM database.

Door Control

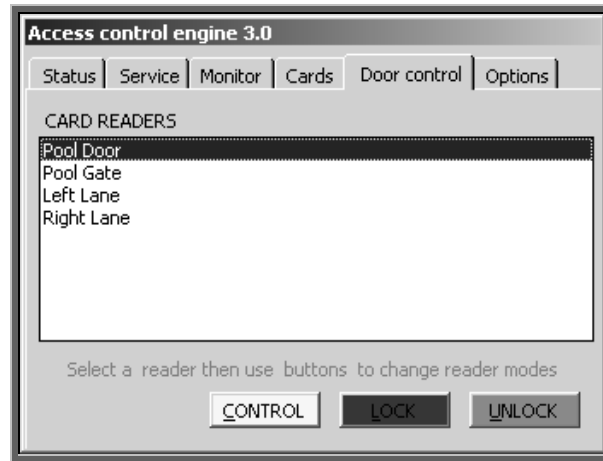

The door control tab shows all the active readers. Underneath the readers are the modes that can be used for the readers. Each door is independent of each other, you simply click on the door or door's you want to change the mode for and select one mode's. The following is a description of each mode:

Control

This is the standard mode that is also known as neutral. Selecting this option puts the system into normal card access mode. Yellow box is displayed around the "Reader" box.

Lock

This locks down the door until the mode is changed back to "control" or "unlock". Even if the resident has a valid card, the door will not open because it's been manually "locked". Red box is displayed around the "Reader" box.

Unlock

This unlocks the door, and anyone can pass through this door until it's put back in "control" or "locked" mode. Green box is displayed around the "Reader" box.

You can temporarily check the status of each door by viewing it from the "reader" mode. In the following example we have "locked" the Pool Door. You can't see it in the picture, but there is a **red box** around the card access 3.0 box.

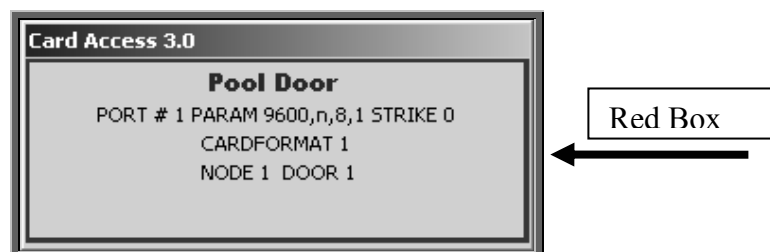

Options

The options tab allows special configuration options to be set specific to the environment.

Options

Skip local updates – Won't automatically look for new updates if this is checked.

Enable Package alerts – Optional signaling to the cardholder when a package is waiting.

Enable package alert relay – Optional local relay that gets activated for the above option.

Enable direct logging mode – Alternate method for logging ACM activity

Engine Mode

Array – Default operation mode for the ACM engine, provides the most efficient operation.

Sparse Array – Optimizes uses of ram on very large databases

Database – Allows for using very large card numbers or very large values as a card identifier.

EXPIRATION TEST: - How often it checks for expired cards (in daytime hours). When the card expires, when does it stop allowing access into the community?

DATABASE: How often it checks the database for new or deleted cards

NODE ID: Unique identifier for each node of the ACM

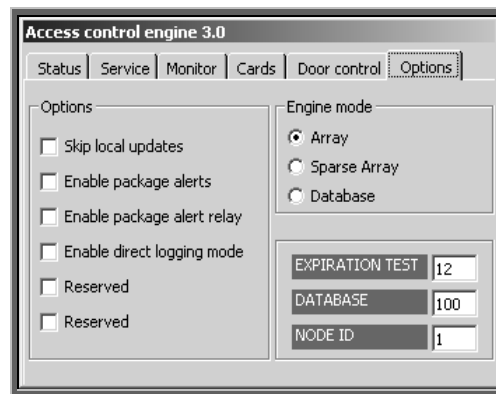

There are a few additional commands that can be performed from the ACM engine. If you right-click on the ACM, you get the menu, if you select “Operations”, you will get 2 additional options



Update Cards

This will automatically update all of the cards that have been recently entered into the database file, but have not been read-into the ACM. This process takes place automatically every 10 minutes or so via the ACM, but in some cases, you can force this to happen immediately by select update cards.

Update Configuration

Very similar to how the “Update Cards” feature works, this updates any changes that have taken place in the configuration of the ACM itself. This includes features such as adding new nodes, changing access levels, etc.

Door control

The door control option from the ACM is the same as the Door Control from the Configure tab. Just that it’s presented slightly different in view.

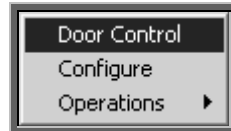

Readers.exe

This is tightly integrated with the ACM engine; basically the readers.exe program is the mini-application that displays the following dialog messages:

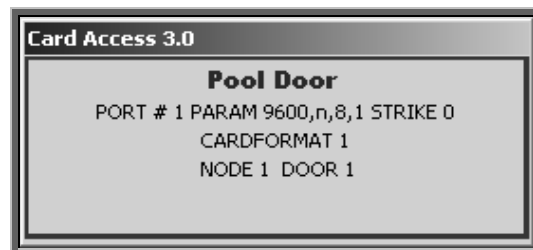

Accesslog.exe

The acceslog is the mini-application that records the data to be used for reports. Most of the functionality of this mini-application runs behind the scenes.



Notice the “Config” under this you will find the following menu

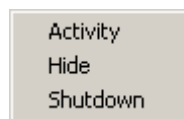

Activity

This is monitor that’s the database interaction with the software, it will display

Hide

This “hides” the Accesslog.exe mini-app from the user’s view. This is the standard mode of operation unless the user specifically

Shutdown

This is to shutdown the Accesslog mini-app. You may ask why you want to shut this down separately, as opposed to shutting down the whole machine. The answer is because you may need to work with the database to correct a problem and you won’t have exclusive rights to the database as long as the Accesslog.exe application is still running.

Lim.exe

This is another mini-application that mainly works behind the scenes. The function of this mini-application is basically, to keep track of the events that occur when the network connection is not available. When the network connection is restored, this application will copy all the data back into history files. This entire process is transparent to the user and no intervention is required.

Chapter 5

Synchronizer – Link

Link is an important option of the ACM configuration. This allows a system with more than 1 gate to be able to see up to 3 other gates from 1 main console or each gate being able to see the status of the other gates. While we won't go into specifics on the Synchronizer since this is all covered in a separate manual, we will go into what needs to be configured to allow effective operation of the Link command.

Upon going into the configuration mode on the Synchronizer, you will click on the link tab and enter the IP address (or machine) name of the machine you're expecting the data from.

The Remote Address field is the place where you would put the IP of the machine you want to get the data from.

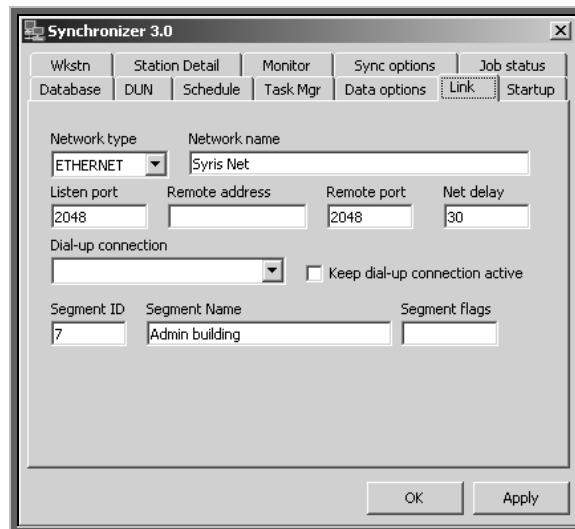

The screenshot shows the 'Synchronizer 3.0' configuration window with the 'Link' tab selected. The window has a menu bar with 'Wkstn', 'Station Detail', 'Monitor', 'Sync options', and 'Job status'. Below the menu bar is a sub-menu bar with 'Database', 'DUN', 'Schedule', 'Task Mgr', 'Data options', 'Link', and 'Startup'. The main configuration area contains the following fields:

Network type	Network name
ETHERNET	Syris Net

Listen port	Remote address	Remote port	Net delay
2048		2048	30

Dial-up connection

Keep dial-up connection active

Segment ID	Segment Name	Segment flags
7	Admin building	

At the bottom of the window are 'OK' and 'Apply' buttons.

Chapter 6

Troubleshooting

When you encounter difficulty, the following steps will be useful in determining the problem you are having.

Types of Problems

When viewing reports you may notice that the reporting function has stopped.

Verify that the Accesslog mini-program is loaded and running. At the main console, right-click the ACM engine, choose configure, select “Service”, and click “Show Readers”. This will pop-up small boxes that display each individual reader in a window of it’s own. You will also see a small window (possibly behind another window), which we refer to, as “Accesslog”. The picture below displays the Accesslog mini-program. **IF, UPON CLICKING “SHOW READERS”, THE FOLLOWING WINDOW DOES NOT APPEAR AND YOU ARE SURE IT’S NOT BEHIND ANOTHER WINDOW. You will need to manually start the “Accesslog” mini-program**



There are several ways of doing the following; this is the easiest method to accomplish this task. Click the Windows START button; select the “Run” command. Type the following inside the open prompt: (assuming the program is installed in the following location) “C:\Program Files\ACTLSERVICE\Accesslog.exe”. Once the mini-program starts, you may “hide’ this window by clicking on the Config menu and select Hide. This application will still be running but it’s hidden.

Notice the “Config” under this you will find the following menu

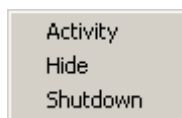

ACM Configuration changes don’t get saved

You **MUST** select “SAVE Changes button” after making **EACH** change.

Chapter 7

Tutorial

Assigning Access Cards

Assigning an access card to a resident is normally done thru the Administrative Interface. After displaying the resident record, the administrator would click the Cards icon to display the “Card Access” screen. The user would then enter the card I.D. number and select which access level to assign to the user. In most cases, access level is “Residents”, but in some developments, you may also find “Security” and “Service People” as options that can be selected. Click the SAVE button in the Card Access Screen to store any of the changes you made in the system.



Normally you would use the Administrative Interface to assign access cards, but with the ACM module, you can easily accomplish this task. The ACM can be used as a stand-alone system, meaning the GateHouse® Administrative Interface is not a required part for the ACM to function. The administrator would click the Cardholders icon on the tree on the left side of the screen and to the right is a tab where the administrator can enter the card number, name of person, level of access, and when the card is active and expires.



- 1 Click the Cardholders icon; the right side of the screen will display 3 tabbed windows.
- 2 Click the Card Number/Name field.
- 3 Enter the name of the cardholder or the number of the access card.
- 4 Enter or select which access level the cardholder will be assigned.
- 5 Enter the date when the card is set to be active.
- 6 Enter the date when the card is set to expire.
- 7 Click the save button to save the changes you made.

The following table describes the additional fields in the cardholder section.

In this field	Do this
----------------------	----------------

Card Number	Enter the number of the access card.
Cardholder Name	Enter the cardholder name.
Clearance	Select which clearance or access level for the card.
Activates	Enter the day and time when the card will be active.
Expire	Enter the day and time when the card will expire.

Facility Code

The access cards residents use to enter the community have an extra series of numbers. This extra number represents the facility code. The purpose of this extra code is so a resident that has a card number in a community can't use the same card to gain access to another community. The facility code makes each card unique to their system.

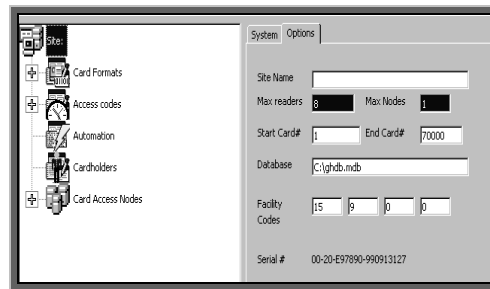

The Access Control system can support four different facility codes. In the site icon, the administrator can add a new facility code or change an exiting one.

To enter a new Facility Code, do the following.

- 1 Click the site icon to display the tab fields.
- 2 In the facility code field, enter the number of the new facility code.
- 3 Click the save button to save the current changes.

Note: If you change the facility code to the wrong code, none of the cards will work.

Changing the Access Card range

The administrator may see an error message stating “access card out of range”. Meaning the access card is outside of the card range that was programmed in the system. In the site icon, there is a field, which defines the range of the cards. In the screen below, the current starting number is 1 and ending card number is 70000.

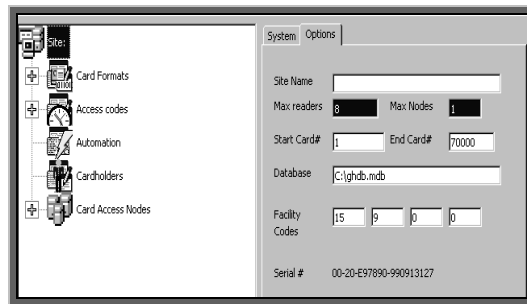

If the card in question has a number greater than 70000, the error message “card outside of range” will appear. To correct this problem, change the end card number to a higher number. Now the card can be used.

The same will happen if the administrator orders a new set of access cards and the starting and ending number are outside the current card range; this will generate an error message.

To enter a new end card number, do the following.

- 1 Click or highlight the end card # field.
- 2 Enter the new number.
- 3 Click the save button to save the new changes.

This completes a very basic tutorial of using the Access Control Module.

Chapter 8 Connection Diagrams

Gatehouse Amtech Connection Diagram

GATEHOUSE AMTECH CONNECTION DIAGRAM

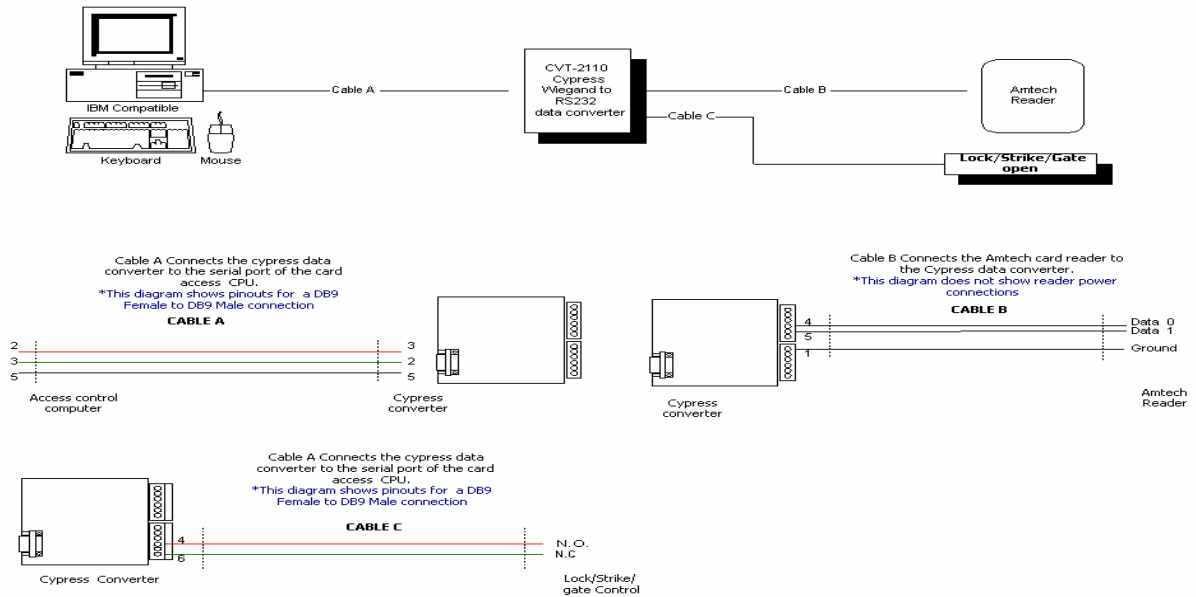

Cypress Board Power Connections

CYPRESS CVT- 2110 POWER CONNECTIONS

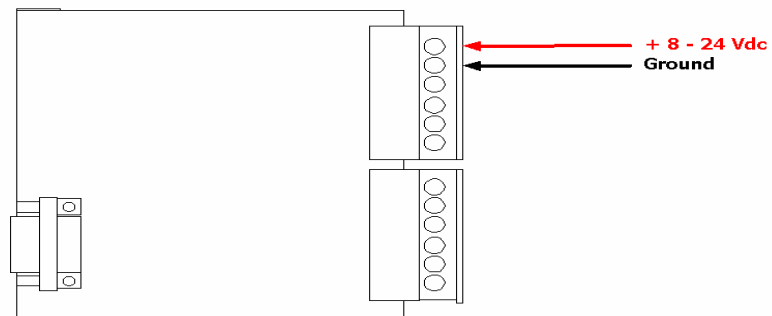

Cypress CVT-2110 Amtech Data Connection

CYPRESS CVT- 2110 Amtech Connection

